

oex
GAME













GAME CHAIR GC•200

MANUAL DO USUÁRIO

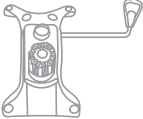
CARACTERÍSTICAS

- Produzida em couro PU, espuma, PVC e tecido
- Parte da estrutura em madeira compensada
- Densidade da Espuma: 24D
- Descanso do braço: PP
- Tipo de mecanismo: Padrão Borboleta
- Função Balanço: 15°
- Bloqueio de inclinação
- Ajuste de altura: 80mm
- Elevação a gás com cobertura de poeira
- Tipo de Base: Nylon 320mm
- Tamanho da rodinha: 50mm
- Material da rodinha: PU
- Cilindro padrão: Classe 2
- Peso máximo recomendado: 100kgs

COMPONENTES

A*1 	G*5 
B*1 	H*1 
C*1(L)*1(R) 	I*4 M6*20 
D*1 	J*4 M6*30 
E*1 	K*4 M8*40 
F*1 	L*4 
M*1 	

Estes são os componentes necessários para montar a sua Game Chair (CG200). Confira na embalagem os pacotes nomeados com as respectivas letras:

- A - Encosto
- B - Assento
- C - 2 apoios de braço
- D - Mecanismo de ajuste
- E - Cilindro de gás
- F - Base
- G - Rodinhas
- H - Plástico de acabamento
- I/J/K - Parafusos
- L - Acabamento
- M - Chave Allen

MONTAGEM

1

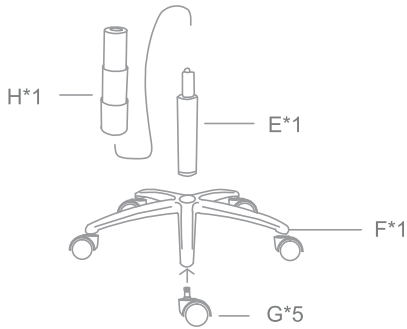

Coloque as rodinhas (G) na base (F). Estas são encaixadas com pressão. Encaixe o cilindro de gás (E) na base e coloque o plástico de acabamento (H) sobre ele.

2

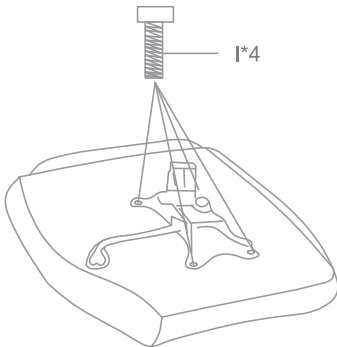

Insira o mecanismo de ajuste (D) no assento (B) e fixe os parafusos (I) com o auxílio da Chave Allen (M).

3

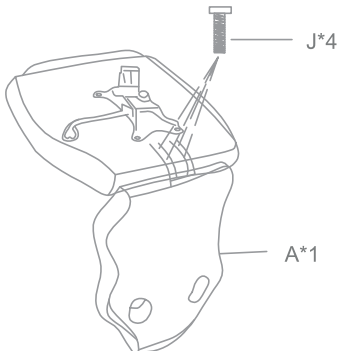

Fixe o encosto (A) utilizando os parafusos (J).

4

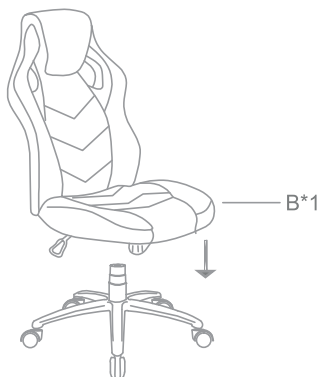

Encaixe o assento (B) no cilindro de gás (E).

5



Posicione os braços (C) nos assentos e utilize os parafusos (K) para fixá-los.

6

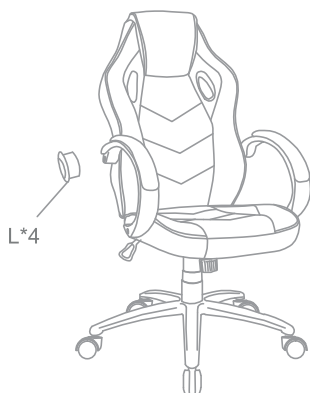

Finalize com o acabamento (L) e aperte bem todos os parafusos para garantir a segurança da montagem. Sua cadeira está pronta para uso!



0800-8870-505
sac@orangeexperience.com.br



oexgameoficial